

Carboning tester



Printed materials must meet a number of criteria in order to exhibit the quality desired by the customer. There are many factors that influence the quality of a printed product. Directly controllable quality features that can be defined and influenced by the printer during production include inking, print contrast, register, drying, and consistency with the original (proof).

There are also quality features that cannot be directly controlled, and cannot be monitored or influenced during the printing process.

These well-known printing phenomena include “rub-off” and “carboning”.

Problems often result from these effects. The printer may have produced a perfect product, but later it turns out that in the folder, during stacking, transport, or processing in the collator, or in the trimmer, rub-off and/or carboning has greatly reduced its quality or even made it completely unusable.

To limit these potential problems or their repercussions, the printer must analyze the customer’s quality requirements and specifications as soon as the order is accepted, and determine whether the order can be completed properly, or whether any protective measures need to be taken against rub-off and/or carboning.

Rub-off or carboning?

Rub-off and carboning differ in terms of cause and appearance, and should therefore be considered independently of one another. A printed product with good rub resistance can exhibit severe carboning; and vice versa, one with poor rub resistance can give good results in a carboning test.



Definition of rub-off

The term “rub-off” is used when the ink film becomes rubbed away against unprinted or printed paper under relatively light pressure. Rub-off occurs mainly when printed sheets are transported, and when printed sheets are pulled out of a stack into a collator.

Definition of carboning

The term “carboning” denotes micro-scale rubbing of ink against a white facing sheet under heavy pressure with minimal lateral movement, for example in a trimmer. Carboning can be especially severe when bleed illustrations are being cut and the printed sheet is in contact with white paper.

This technical information specifically discusses the carboning phenomenon and the new carboning tester.

Carboning testing

Until recently, the carboning characteristics of a test or practice print run could only be determined subjectively. The procedure was to place the item in question face down on a strip of unprinted material, and scribe a dense cross hatch pattern onto an area about 10 x 10 mm, using an empty ball-point pen, to simulate micro-scale rubbing. The amount of ink transferred onto the un-printed material was then assessed visually.

Because the pressure exerted was not defined, this method produced considerable individual variations and did not yield reproducible and informative results, since each tester would exert a different amount of pressure on the pen point.

Our Physics Laboratory regarded this unsatisfactory carboning test as a technical challenge, and set out to create reproducible testing methods.

Gerolf Niessner and Josef Sutter have now developed a tester that is capable of simulating micro-scale rubbing (= carboning) under welldefined conditions.

Carboning tester

The SYSTEM MICHAEL HUBER MÜNCHEN carboning tester offers an easy, quick, and reproducible way to test the carboning characteristics of printed materials.

The printed page under test is placed face down against a blank sheet of paper, and subjected to a specific high level of linear pressure in the carboning tester.

The detailed procedure for carboning testing with this unit is as follows:

The printed piece of paper (test article) is placed against the blank sheet and inserted between the large roller (4) and small roller (5).

During the test phase, the two test sheets are pressed together under defined pressure (lever arm with adjustable weight).

System Michael Huber München carboning tester in working position

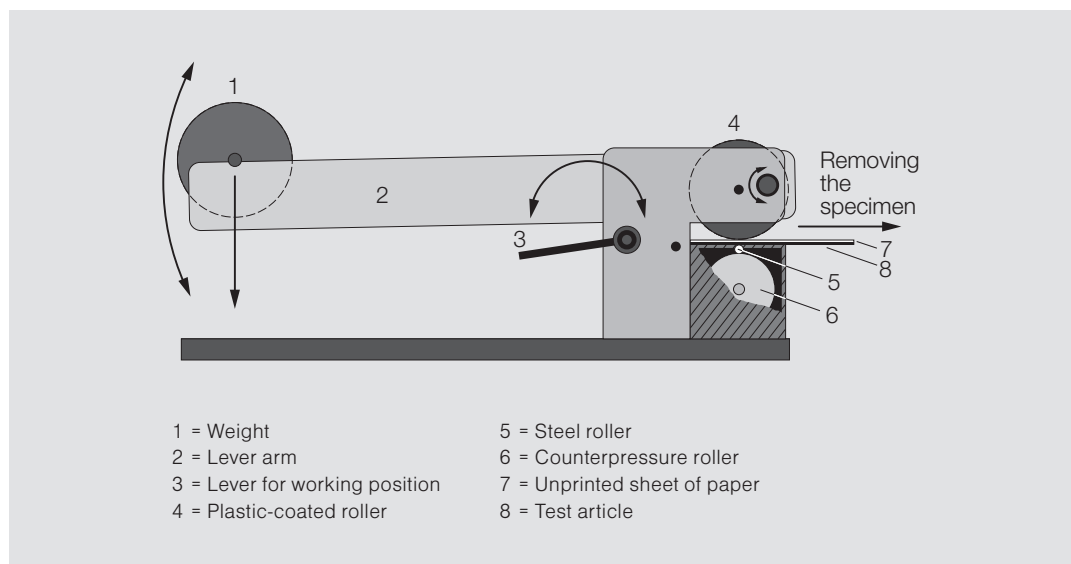

The special flexible plastic coating on the roller (4) and the small steel roller (5) interact to produce a small amount of friction (= micro-scale rubbing = carboning) between the two test sheets (7 and 8) under pressure (working position).

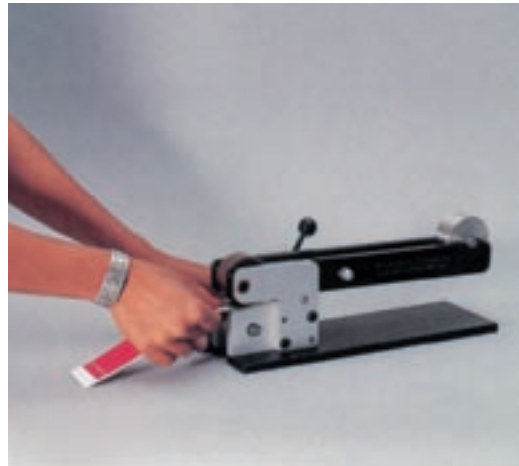
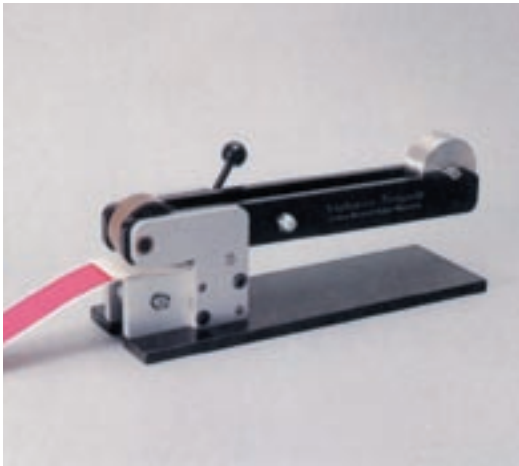

Normally the same paper grades are used for the printed and blank sheets. Once the lever arm has been lowered to the test position, the specimens (blank sheet and test article) are pulled out at a constant rate. The transferred image on the backing material produced by a smooth pull can then be evaluated either visually or mechanically (using a densitometer or colorimeter).

Because instrumental conditions remain constant, the effect can be reproduced at any time.

In addition to carboning testing, the unit can also be used successfully to test write-through characteristics for carbon and duplicating papers.

Results and experience

Our experiments indicate that the carboning characteristics of a dry ink film depend a great deal on the stock. Semi-matt coated papers in particular, regardless of the kind of ink used for printing, exhibit very different carboning behavior (Impressions 1 and 2). Even UV inks, which have a fundamentally different drying system from conventional inks, exhibit carboning on certain stocks. Carboning is much worse when material printed by web or sheet-fed offset has not dried thoroughly.

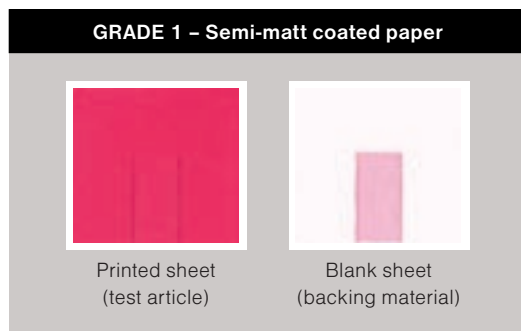

Impression 1
Printed sheet with high level of carboning

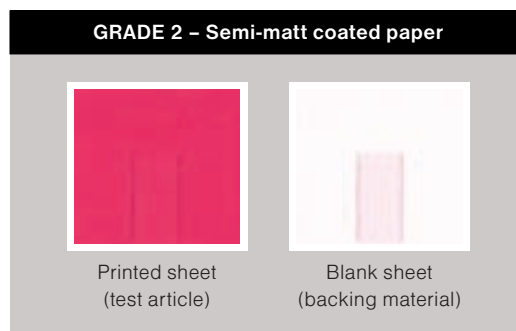

Impression 2
Printed sheet with low level of carboning

Remedies

The problem basically cannot be solved by changing the ink formulation.

Partial varnishing with overprint or dispersion varnish therefore still represents the most reliable preventive measure.

The carboning test can be used to determine beforehand whether varnishing is necessary (Impression 3).

Semi-matt coated paper plus overprint varnishing



Printed sheet
(test article)



Blank sheet
(backing material)

Impression 3

No carboning

However, the nature of the subject being printed must also be considered. Particular attention must be paid to bleed illustrations, especially when printed in dark colors such as black or blue.