

The phenomenon of metamerism

The term “metamerism” is certainly not one that is familiar to the ordinary man or woman on the street even though they have without a doubt come across the phenomenon it describes. All of us have at some time noticed that there are colours which, when compared with an original, produce a good match in daylight but differ greatly when viewed under different lighting conditions. Such effects particularly arise with mixed inks made up from several dyes or pigments, e.g. grey, brown and olive shades, and are referred to as ‘metameric effects’. Those of us who work in the printing industry are regularly confronted with effects of this kind, especially when pigments have to be substituted in order to obtain better fastness values. In these cases, it is impossible to achieve a non-metameric match.

If, for example, the colour proofs of a given colour original and of the mixed ink as shown below are viewed in natural daylight or under a D 5000 daylight lamp*, the two match up rather well. If, however, a printman uses this ink in the press with different, artificial light or a customer looks at the image printed with this ink under a standard fluorescent light, the deviation between the colours is enormous. But it is also possible for considerable colour deviations to arise under different daylight conditions, for instance, when viewing an image in sunlight or under cloudy conditions. Larger objects – such as the walls of a building, green trees and painted interior walls – located in the immediate vicinity likewise influence the composition of incident daylight and can therefore have a great effect on the appearance of a print.

What are the causes of these phenomena and how can they be countered effectively? The chromatic appearance of any object is determined by the manner in which the object alters the light that falls on it: to be more precise, the object absorbs some and reflects the rest of the light incident on it and it is the reflected light that is perceived by the eye as the colour of the object. Our eye picks up the result of the interaction between the object being viewed and the light that falls on it: in other words, our perception of colour can change as soon as either the nature of the object or the light incident on it changes.

Here is an example to explain this phenomenon.

The two olive prints have been produced from inks with a different pigment structure. As a result, they absorb different portions of the incident daylight in line with their respective (pigment-dependent) light absorption capacity. Despite this, the rest of the light they reflect causes the same colour sensation in the human brain because the additive mixture of the light not absorbed produces the same optical result in both cases. The actual difference in nature of the prints becomes immediately apparent, however, when they are viewed under a type of light with a different composition – one also talks of a different spectral energy distribution – such as artificial light. The reflected fractions of the incident light no longer appear the same because ‘Olive II’ absorbs a high level of certain fractions that are found only in small quantities in artificial light. This is why the remaining perceivable parts of the light reflected no longer add up to give our ‘Olive I’ we require, but produce a different colour shade.

* See also section entitled “Correct matching” below



Olive I

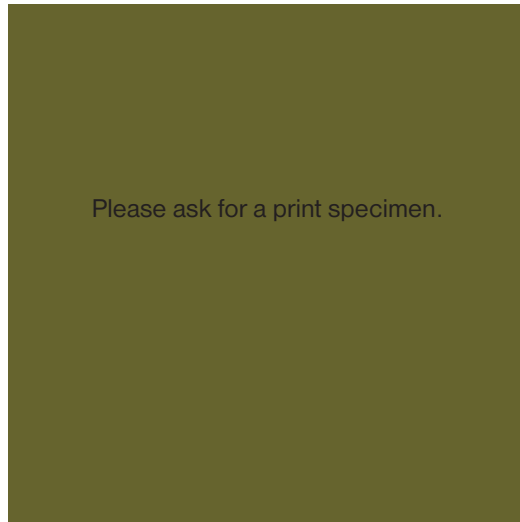

Olive II

Two printing inks that influence the light that falls on them in this way are referred to as “metameric” or as a “metameric match” because they only appear identical when viewed under a certain light source. Colours that do not differ from one another when seen under different light sources are known as “isomeric” colours.

A PRECISE EXPLANATION

What’s known as a “reflectance curve” can be established for every object, i.e. that fraction of incident light that is reflected is defined in small steps for the entire range of visible light (compared with absolute white, which reflects 100%). This is done with the aid of a spectrophotometer.

The curve below shows, for example, that approx. 10% of the light with a wavelength of 400 nm is reflected and 90% is absorbed by the object being measured.

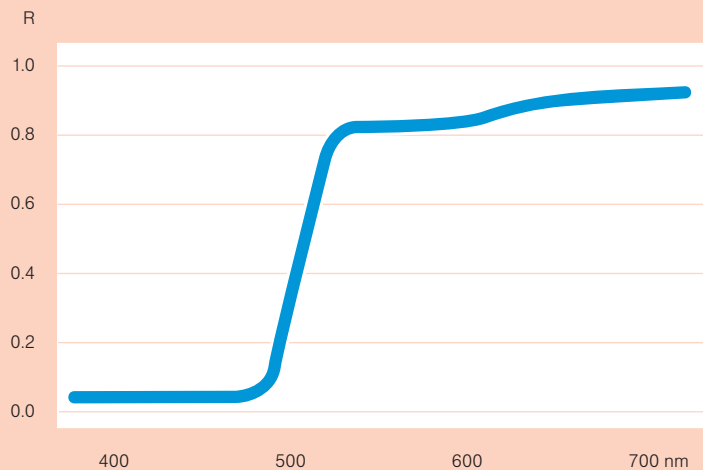

The reflectance curve therefore describes how much of the incident light in the visible range is reflected at the wavelengths in question and is therefore visible to the human eye.

Two dyes, pigments or coloured objects or prints with an identical curve characteristic appear identical to every viewer under every light source. That is easy enough to understand. But why do our two olive shades appear identical in daylight even though they have two clearly different curves?

The answer to this question is to be found in the fact that our eye is not in a position to pick up each wavelength individually but can see only three ranges of the spectrum.

These ranges intersect in such a way that the entire visible spectrum is covered but they leave gaps with a lower sensitivity. The hue perceived overall results from superposition of the light energy that falls on the eye in line with the reflectance curve and the sensitivity of the three colour vision ranges of our eye.

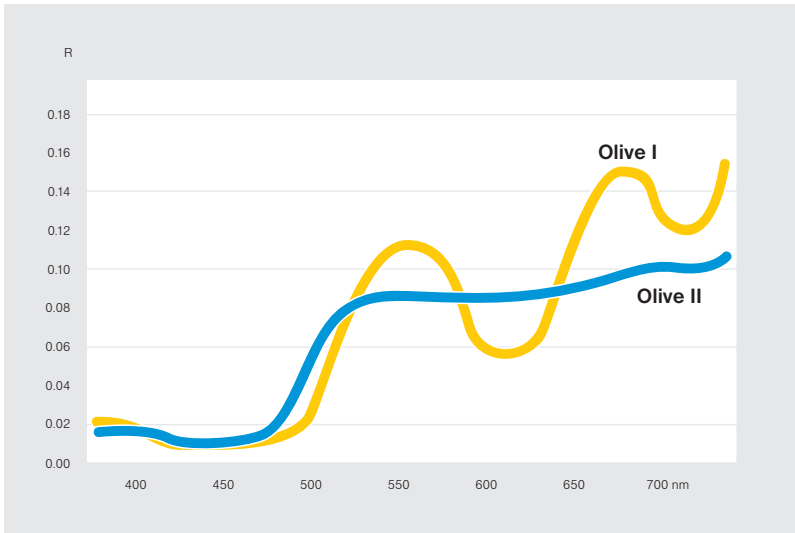

Reflectance curve of the two olive colours shown

Practice shows that the result of such superposition can be the same even for two differently shaped reflectance curves and that this produces identical colour perception. We are also able to quantify the spectral sensitivity of the three stimulation centres of the eye. This enables us to calculate in advance for each pair of curves whether two colours will appear identical to the eye under specific illumination conditions or whether they are different in every case.

What this means in practice

Theoretically, it is possible to create many ink combinations that match up with the colour tone of Olive I in daylight. But as long as such colours are only metameric, i.e. have different reflectance curves, metameric effects can arise that are highly undesirable in practice. The printing industry in particular demands that reproductions of given originals appear identical under all circumstances.

That said, there are certain prerequisites that have to be fulfilled if the “right” pigments, that is, those that produce exactly identical reflectance curves, are to be found:

1. The original in question must contain dyes or pigments that are also suitable for producing printing inks. Artists’ colours, water-colour designs, coloured papers and films/foils frequently do not fulfil such requirements.
2. The original may contain only a limited number of individual dyes or pigments. This is often not the case if, for instance, the original colour has been mixed from several separate colours each of which in turn contained two or three pigments. This is very often the case with grey, brown and olive shades.
3. People’s views as regards an acceptable price and the fastness properties required of the printing ink must be in accordance with the realities of the original. If the fastness properties of a print are to differ from those of the original, we inevitably end up with metameric colours.

If these prerequisites are not fulfilled, we must always reckon with a certain degree of metamerism.

Correct matching

Our visual assessment of colours is influenced by a multitude of factors:

- The type and intensity of the light source.
- The environmental conditions or ambient circumstances (substrate).
- The other hues surrounding a coloured area/surface.
- The size of the coloured area/surface.
- Tiredness on the part of the person examining the colours.
- Differences between persons.

It can frequently be observed when colour matching that different people arrive at different assessments. This is due to the fact that people perceive colour differently from one another (sometimes also due to defective colour vision).

What is important is that matching is conducted under the right conditions. It is not permissible, then, to lean over the sample if it is illuminated from above because the viewer in this way creates a shadow and disturbs the lighting conditions.

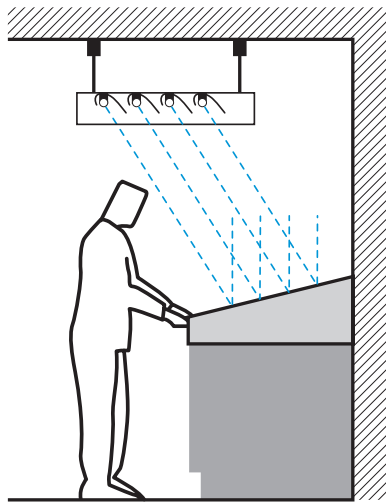

Asymmetrical colour matching lamp

The following is an extract taken from the FOGRA standard, which explains the correct lighting conditions for colour matching:

Work instruction 16 A

Selecting and Installing Colour Matching Equipment

When purchasing colour matching lamps, always make sure that they fulfil the conditions of ISO 36664:2000 (1.6-1) with respect to condition P1, that is, that they have a colour temperature of 5000 °K and an irradiation level of 2000 lx. Furthermore, ask the manufacturer how long the useful life of the lamps is.

Install a time meter.

Ensure that no extraneous light worthy of mentioning falls on the installation location, above all no coloured light. Any extraneous light should amount to no more than 25% of overall light incidence, measured using a luxmeter.

Check whether dazzling light sources are positioned in the field of vision of the person conducting colour matching and switch off any such sources.

Use a luxmeter to test the uniformity of illumination in accordance with the conditions set down in paragraph 2 of the requirements.

Define intervals for cleaning and replacing the lamps that belong to the colour matching equipment and observe them with the aid of the time meter. If, for example, the useful life of fluorescent lamps is stated as being 2000 h, define the inspection interval as 500 h, after which time you should clean the equipment and replace one quarter of the lamps with new ones. Each lamp must be marked to indicate how many hours it has been in operation (one mark made with e.g. a marker pen for every 500 h). Follow the same procedure at the end of the next 500 h. Lamps that carry more than 3 marks must be used for normal lighting somewhere else on the premises. The procedure described ensures that the colour temperature of the lighting used for colour matching purposes will always remain constant. You will experience no abrupt changes in the lighting conditions as would be the case if all lamps were changed after 2000 h.